

FEATURES

- All SS measuring system
- Socket-case, direct welded
- Dry / liquid filled
- CE marking

APPLICATION

- Liquid & gaseous mediums
- Corrosive environments
- Oil & Gas applications
- Chemical & Petrochemical
- Food & Beverages
- Nuclear power plants

Bourdon Tube, \geq DN100



STANDARD PARAMETERS

Accuracy	: CL 1.0
Ambient temperature	: -40...+65°C (without dampening liquid)
	: -20...+65°C (with dampening liquid)
Service temperature	: 300°C max.
Pressure limits	: Steady pressure up to FS value
	: Fluctuating pressure up to 90% of FS value
	: Short time 1.3 x FS value for range up to 100 bar
	: Short time 1.15 x FS value for range above 100 bar
Weld joints	: TIG argon arc welding

MATERIAL OF CONSTRUCTION

Sensing element	: Bourdon Tube (<100 bar : C - type , > 100 bar : Helical)
Case & Ring material	: AISI 304 SS (Bayonet type)
Bourdon tube & Shank	: AISI 316L SS (Shank welded directly to case)
Movement mechanism	: AISI 304 SS
Dial	: Aluminum, black graduation on white background
Pointer	: Micro-zero adjustable, aluminum, black powder coated
Gaskets, Blow off disc & filling plug	: Neoprene / NBR
Window	: Sheet glass / Shatterproof safety glass

STANDARD SPECIFICATIONS

Dial size	: DN100 / DN125 / DN150 / DN250
Range	: -1...0...1,600 bar
Mounting pattern	: Direct, Bottom connection
Process connection	: 1/2" NPT (M) / 1/2" BSP (M)
Ingress protection	: IP 54 / IP 65
Execution	: Dry / Dry but fillable**

STANDARD SPECIFICATIONS : DAMPENING LIQUID FILLED, GLYCERIN

Window	: Safety glass
Dampening liquid	: Glycerin 99.7% [Service temperature up to 65°C]

TEMPERATURE EFFECT

When temperature of the measuring system deviates from reference temperature (+20°C) max error $\pm 0.4\%$ / 10K of true scale value.

** DN250 available as standard "Dry" (Code EA) version. For other versions contact factory.

DIMENSIONAL DRAWING

Type B0

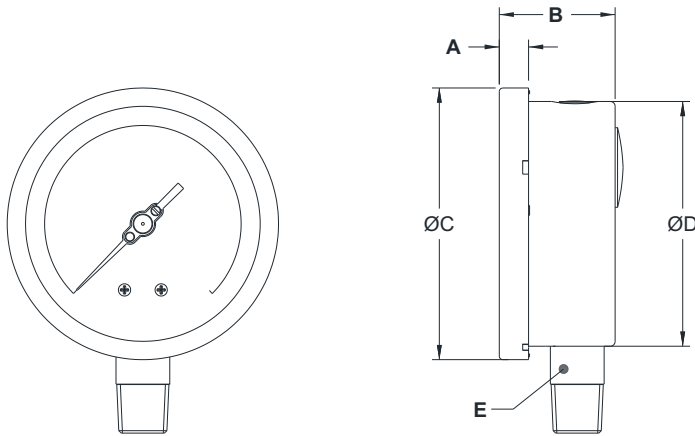

DN	A	B	ØC	ØD	E	Weight (grams)
100	12	48	111	100	SQ.22	506
125	15	48	129	118.5	SQ.22	694
150	15	48	161	149	SQ.22	900
250	18.5	50	263	250	SQ.22	2100

Type B1

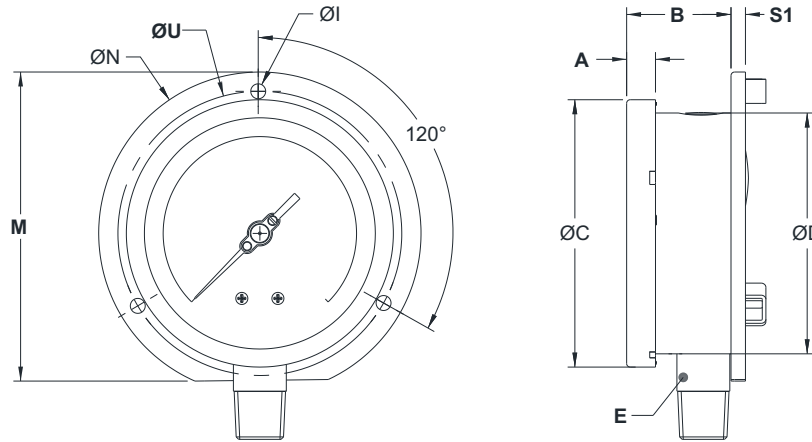

DN	A	B	ØC	ØD	E	ØI	M	ØN	S1	ØU	Weight (grams)
100	12	52	111	100	SQ.22	6	128	134	6	118	613
125	15	50	129	118.5	SQ.22	6	143.5	150	4	137	796
150	15	52	161	149	SQ.22	6	172.4	186	6	168	1080
250	18.5	51.5	263	250	SQ.22	7	286.5	290	1.5	276	2448

Type B2

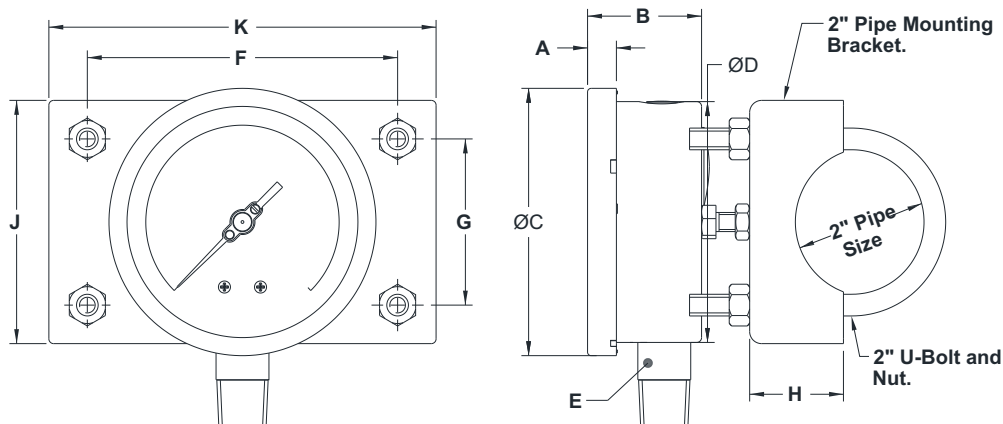

DN	A	B	ØC	ØD	E	F	G	H	J	K	Weight (grams)
100	12	48	111	100	SQ.22	129	69	39	101	161	1580
150	15	48	161	149	SQ.22	129	69	39	101	161	1974

All dimensions are in mm.

DIMENSIONAL DRAWING

Type B3

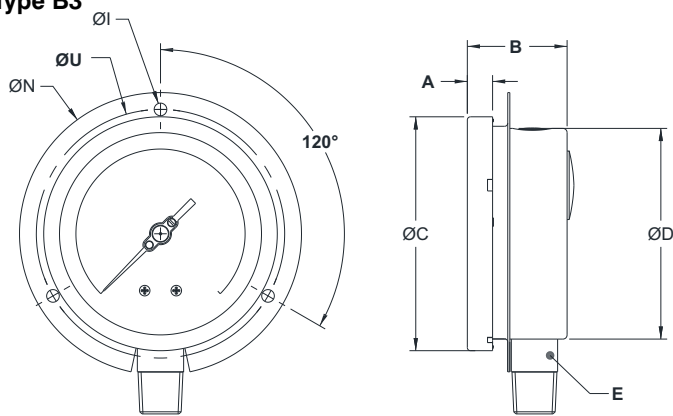

DN	A	B	ØC	ØD	E	ØI	ØN	ØU	Weight (grams)
100	12	48	111	100	SQ.22	6	134	118	580
150	15	48	161	149	SQ.22	6	186	168	2433

Type R0

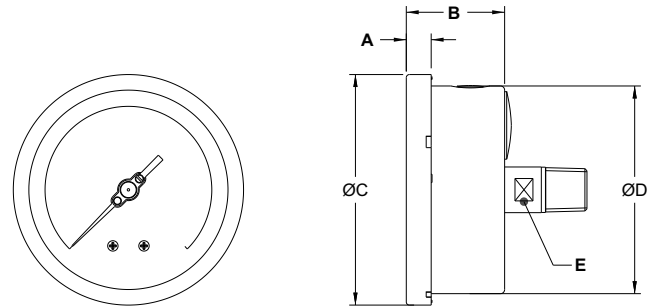

DN	A	B	ØC	ØD	E	Weight (grams)
100	12	48	111	100	A/F 17	506
150	15	48	161	149	A/F 17	2100

Type L0

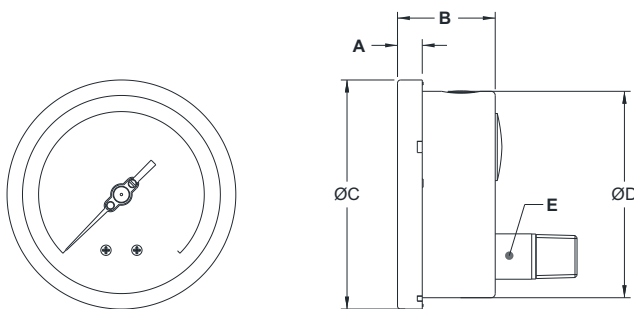

DN	A	B	ØC	ØD	E	Weight (grams)
100	12	48	111	100	SQ.22	506
125	15	48	129	118.5	SQ.22	694
150	15	48	161	149	SQ.22	900
250	18.5	50	263	250	SQ.22	2100

Type L1

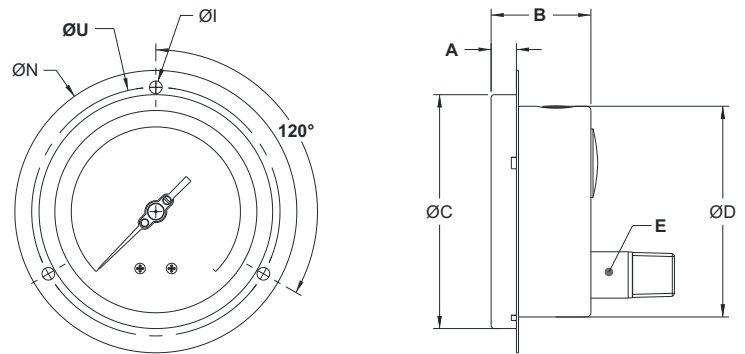

DN	A	B	ØC	ØD	E	ØI	ØN	ØU	Weight (grams)
100	12	48	111	100	SQ.22	6	134	118	580
125	15	48	129	118.5	SQ.22	6	150	137	770
150	15	48	161	149	SQ.22	6	186	168	1016
250	18.5	50	263	250	SQ.22	7	290	276	2433

Type L2

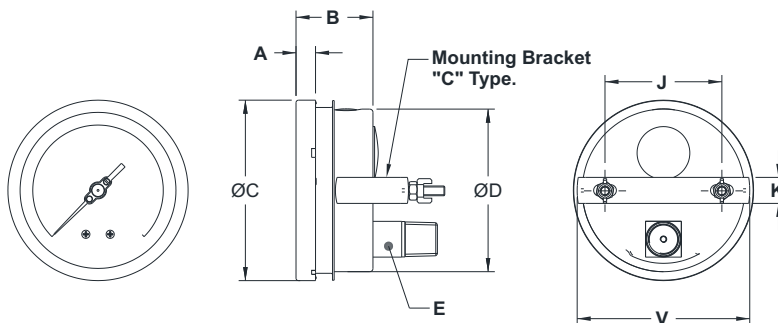

DN	A	B	ØC	ØD	E	J	K	V	Weight (grams)
100	12	48	111	100	SQ.22	72	16	108	595
125	15	48	129	118.5	SQ.22	75	15	125	790
150	15	48	161	149	SQ.22	106.5	16	158.5	1066
250	18.5	50	263	250	SQ.22	180	30	270	2310

RANGE V/s OVER RANGE

RANGE "bar"	OVER RANGE "bar"
0...1	4
0...1.6	6
0...2.5	10
0...4	16
0...6	25
0...10	40
0...16	48
0...25	75
0...40	80
0...60	120
0...100	200
0...160	320
0...250	500
0...400	800
0...600	1200

ORDERING CODES

1. DIAL SIZE

04	100 mm / 4"
05	125 mm / 4½"
06	150 mm / 6"
10	250 mm / 10"

04

2. RANGE

XXX	Refer "Range Table"
------------	---------------------

XXX

3. MOUNTING PATTERN

B0	Direct, Bottom connection
B1	Wall/Surface/Projection mounting, Bottom connection
B2	2" Pipe/Yoke mounting, Bottom connection
B3	Panel/Front flange mounting, Bottom connection (available in DN100 / DN150)
R0	Centre, Back connection ²
L0	Lower, Back connection
L1	Panel/Front flange mounting, Lower Back connection
L2	Panel/bracket mounting, Lower Back connection

B0

4. PROCESS CONNECTION

12B	¼" BSP (M)
12N	¼" NPT (M)
13B	3/8" BSP (M)
14B	½" BSP (M)
14M	M20 X 1.5 mm (M)
14N	½" NPT (M)

Other thread size and standards available on request.

14N

5. INGRESS PROTECTION

ER	IP 65
ES	IP 66
ET	IP 67

ER

6. EXECUTION

EA	Dry ⁴
EB	Dry but fillable
EG	Dampening liquid filled, glycerine
EH	Dampening liquid filled, silicon oil

EB

7. OTHER OPTIONS

BA	Case & Ring in AISI 316 SS (B0)
BB	Case & Ring in AISI 316 SS (B1)
BC	Case & Ring in AISI 316 SS (B2)
BD	Case & Ring in AISI 316 SS (B3)
BG	Case & Ring in AISI 316 SS (R0)
BK	Case & Ring in AISI 316 SS (L0)
BL	Case & Ring in AISI 316 SS (L1)
BM	Case & Ring in AISI 316 SS (L2)
EM	Dampening screw, Monel
EN	Dampening screw, AISI 316 SS
EX	Internal overload stop
EY	Internal vacuum stop
EZ	Pointer stop on dial
E8	Eco version ⁷
G9	Dial with Freon temperature scales
GB	Plexi glass
GC	Shatterproof safety glass
GD	Toughened glass
GL	AISI 316 SS movement
GM	Dampened movement
GW	Maximum Reading pointer ³
GX	Knife edge pointer
MN	Monel wetted parts
N9	Dial with Ammonia temperature scale
OP	Overrange protection 1.5xFS
OS	High overpressure protection ⁸
P8	Epoxy coating (Case & Ring)
R9	Receiver gauge ⁴
RA	Rubber parts, Viton
RW	Vent plug, ON-OFF type
TA	5 - point calibration certificate
TC	Material test certificate 3.1
TE	CE certificate
TI	IBR certification
TL	Helium leak testing
TM	Material test certificate 2.2
TN	Tested to NACE standards
TO	Certification for Oxygen service
TP	Performance test
TT	C.C. with NABL traceability
XA	Accuracy CL 0.5 / CL 0.6 of FS
XF	SS tag plate, AISI 304 SS
XG	SS tag plate, AISI 316 SS
XK	Electro polished (Case & Ring)
XN	Anti-parallax mirror band
XR	Custom designed dial
XT	Dial tag marking

XX

Ordering Example : P101-04-XXX-B0-14N-ER-EB-BA

NOTES

- For other connections, please contact factory.
- Available in dry version with accuracy CL 1.0 or above.
- Available in dry version with accuracy CL 1.0 or above.
- Available with Ingress Protection IP 54 (dust proof) only.
- Supplied with AISI 304 SS wetted parts, fix pointer, single color dial & accuracy CL 1.6.
- Available in DN100 only.
- Please specify the second scale required.
- C.C. = Calibration Certificate
- Refer Range V/s Overpressure table.